

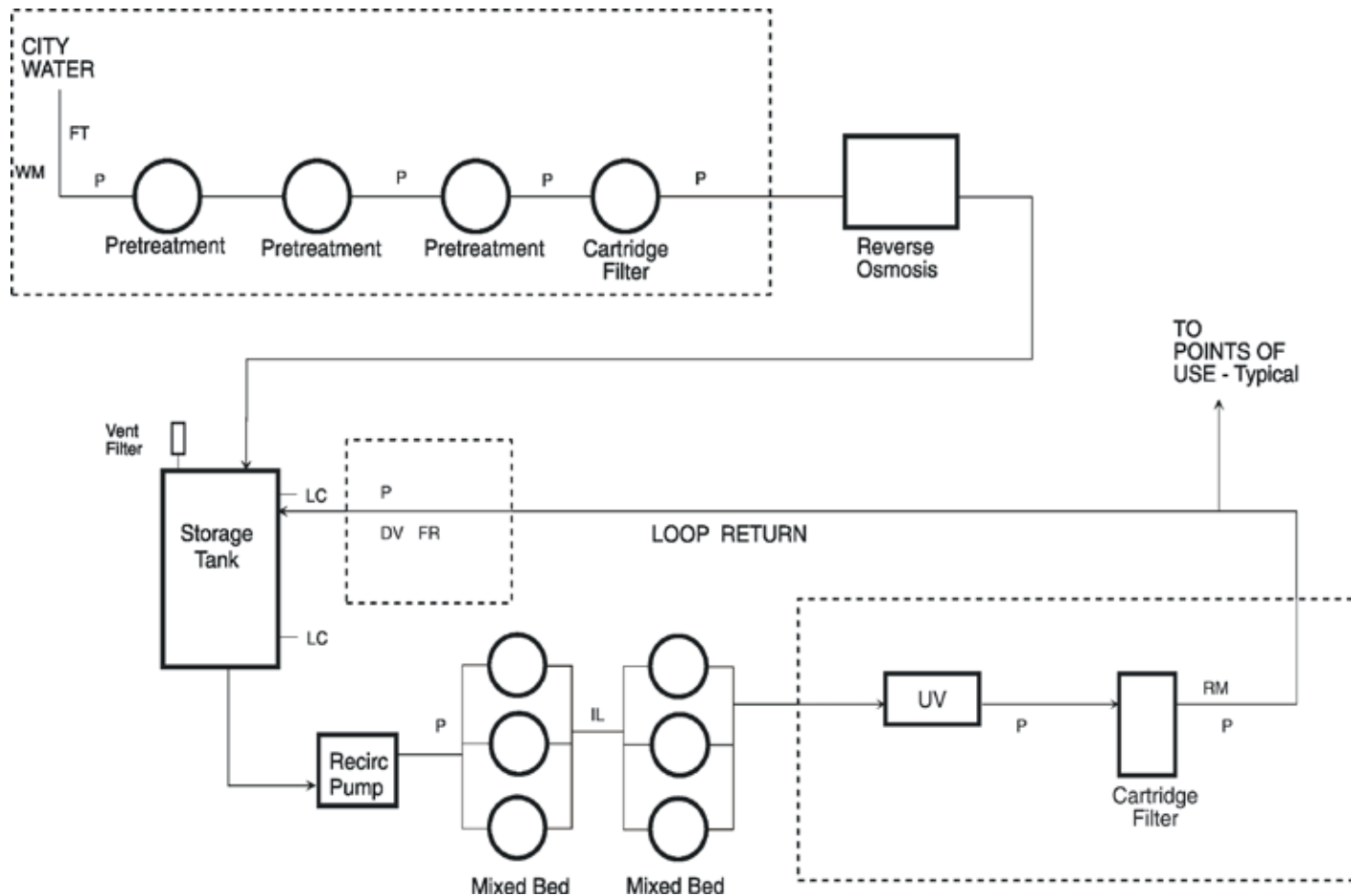

Industrial Water Purification Systems

High Purity RO DI System



KEY

- UV - ULTRA-VIOLET UNIT
- PG - PRESSURE GAGE - Tri-Clover
- CV - CHECK VALVE
- FM - FLOW METER
- DV - DIAPHRAGM VALVE
- WM - WATER METER
- SP - SAMPLE PORTS
- SOV - SOLENOID VALVE
- RV - RELIEF VALVE
- T - THERMOMETER
- UV - ULTRAVIOLET UNIT
- FCV - FLOW CONTROL VALVE
- FM - FLOW METER, TOTALIZER
- FT - FLOW TOTALIZER
- CHL - CHLORINE SAMPLER
- FS - FLOW SWITCH

System Description

This very general schematic can actually be used as a High Purity Water System for many applications in electronics and printed circuit work.

It can be used for different approaches using different materials of construction and different QC requirements.

FILTERS, WATER & INSTRUMENTATION, INC.
www.FiltersWater.com
23 Londonderry Road, Unit 13
Londonderry, NH 03053
PH 603 434-9577 FX 603 434-2832