

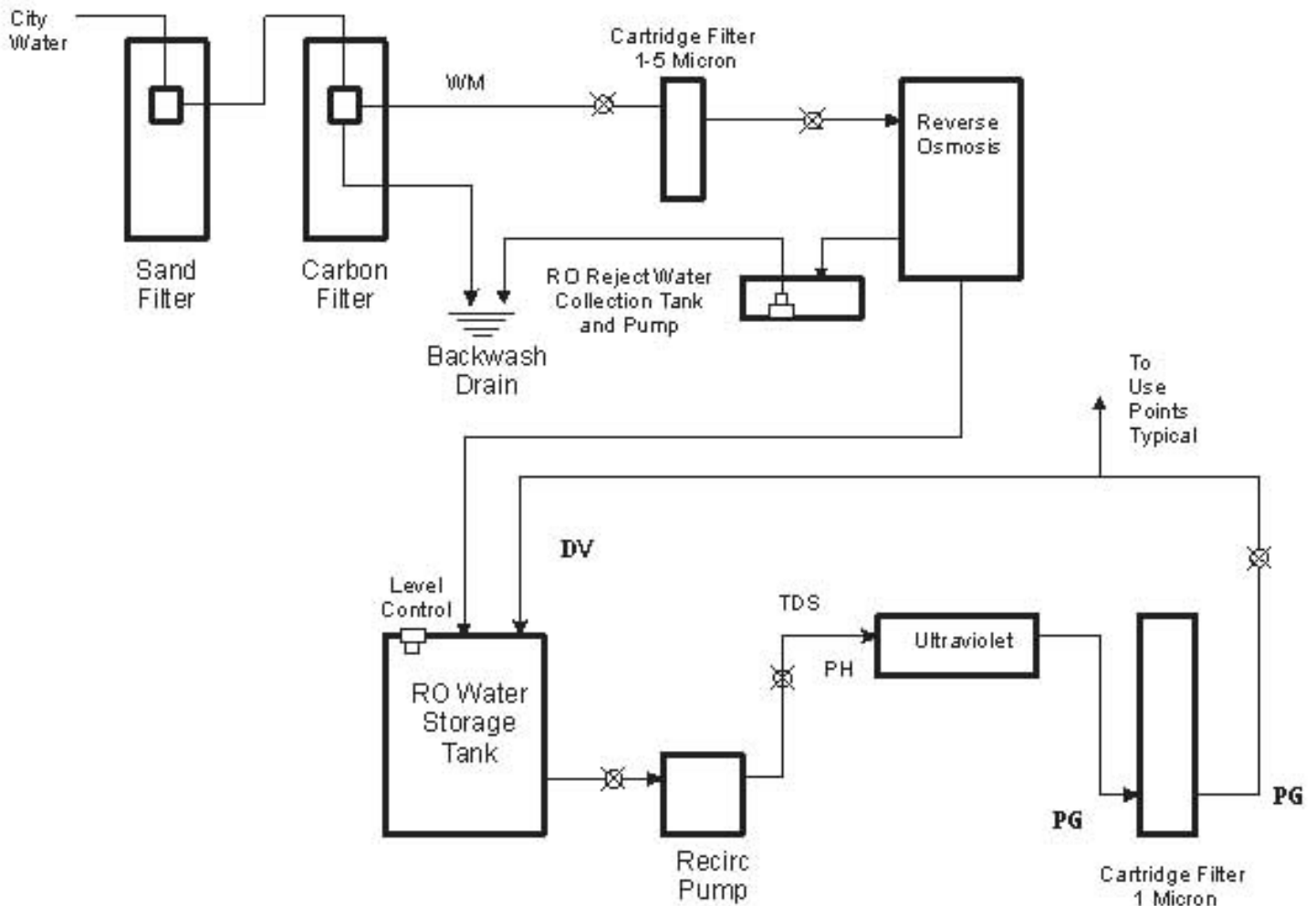

Industrial Water Purification Systems

Food and Beverage Water RO System



KEY

UV - ULTRA-VIOLET UNIT
 PG - PRESSURE GAGE - Tri-Clover
 CV - CHECK VALVE
 FM - FLOW METER
 DV - DIAPHRAGM VALVE
 WM - WATER METER
 SP - SAMPLE PORTS
 SOV - SOLENOID VALVE
 RV - RELIEF VALVE
 T - THERMOMETER
 UV - ULTRAVIOLET UNIT
 FCV - FLOW CONTROL VALVE
 FM - FLOW METER, TOTALIZER
 FT - FLOW TOTALIZER
 CHL - CHLORINE SAMPLER
 FS - FLOW SWITCH

System Description

This System removes dissolved minerals from the incoming city water stores the water and preserves its bacterial free state through UV and with the loop pressure from the system pump makes the water available throughout the facility.
 Some call this a proofing water as the water is used to dilute the pure spirits to the correct proof.

FILTERS, WATER & INSTRUMENTATION, INC.
www.FiltersWater.com
 23 Londonderry Road, Unit 13
 Londonderry, NH 03053
 PH 603 434-9577 FX 603 434-2832