

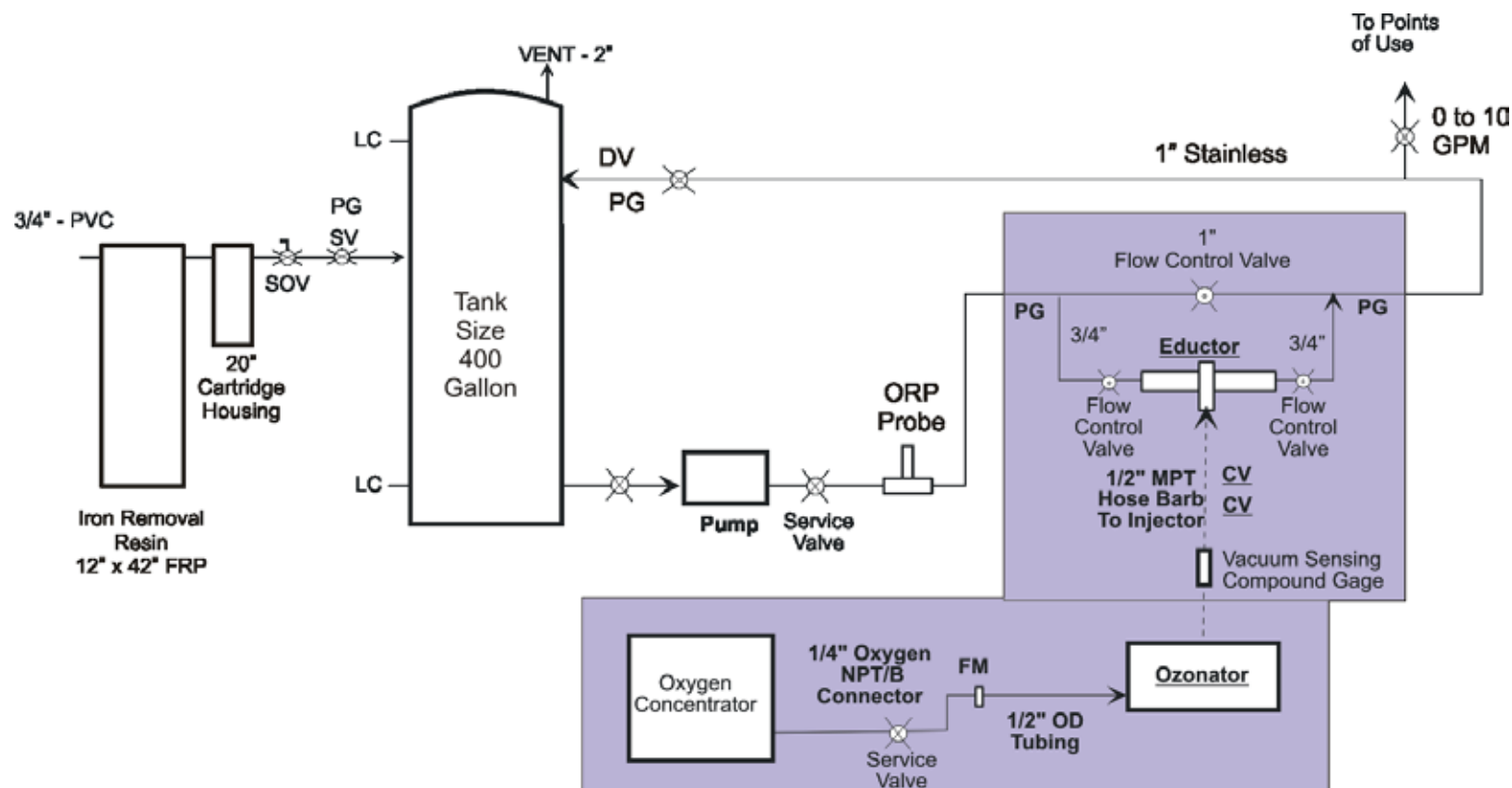

Industrial Water Purification Systems

Food and Beverage Bottled Water Ozone System



KEY

- UV - ULTRA-VIOLET UNIT
- PGB - PRESSURE GAGE BRASS
- PGSS - PRESSURE GAGE 316 STAINLESS
- IL - INDICATOR LIGHT
- RM - RESISTIVITY PROBE
- CV - CHECK VALVE
- FM - FLOW METER
- DV - DIAPHRAGM VALVE
- WM - WATER METER
- SP - SAMPLE PORTS

System Description:

This System removes Iron and particles from a well water supply. We store the water and recirculate adding ozone for the bottled water process.

The Ozone loop also provides water to the filler for bottling.

In this instance we use ORP to regulate the amount of Ozone produced by The Ozone.

FILTERS, WATER & INSTRUMENTATION, INC.
www.FiltersWater.com
23 Londonderry Road, Unit 13
Londonderry, NH 03053
PH 603 434-9577 FX 603 434-2832